

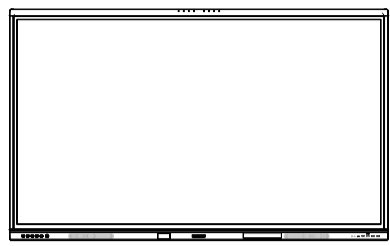

Contents



LCD Display



Remote Control and AAA Batteries



Power Cable

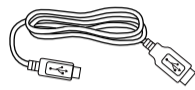

Touch USB



Stylus x 2

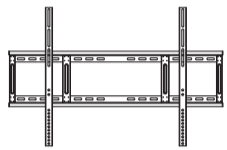

Wall Mount Bracket



CRD33 Wireless Module



Quick Start Guide

* Differences according to regions.
Display design and accessories may differ from those illustrated above.

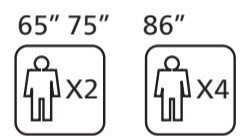

Not included:

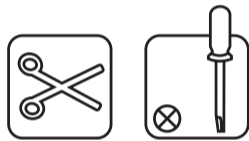

1 Unboxing

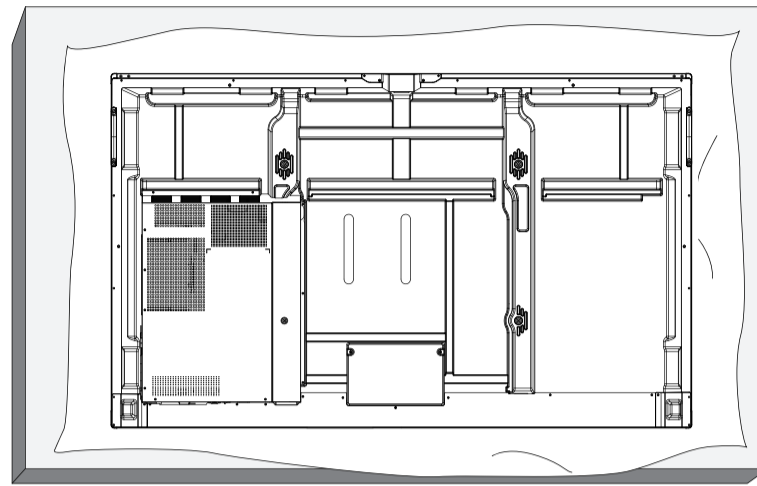
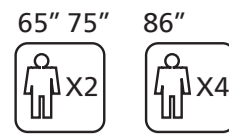

2 Control Panel

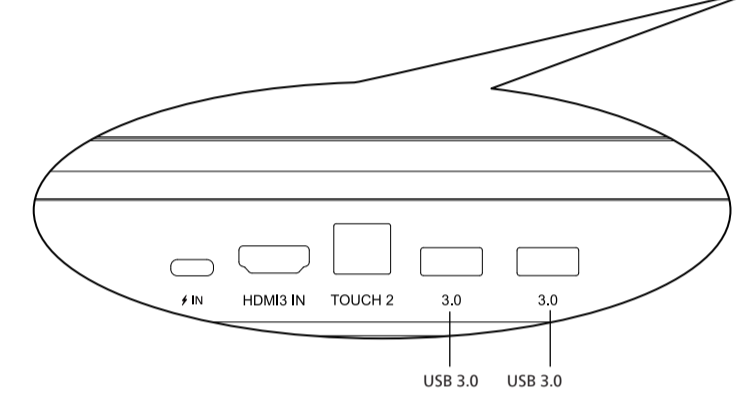
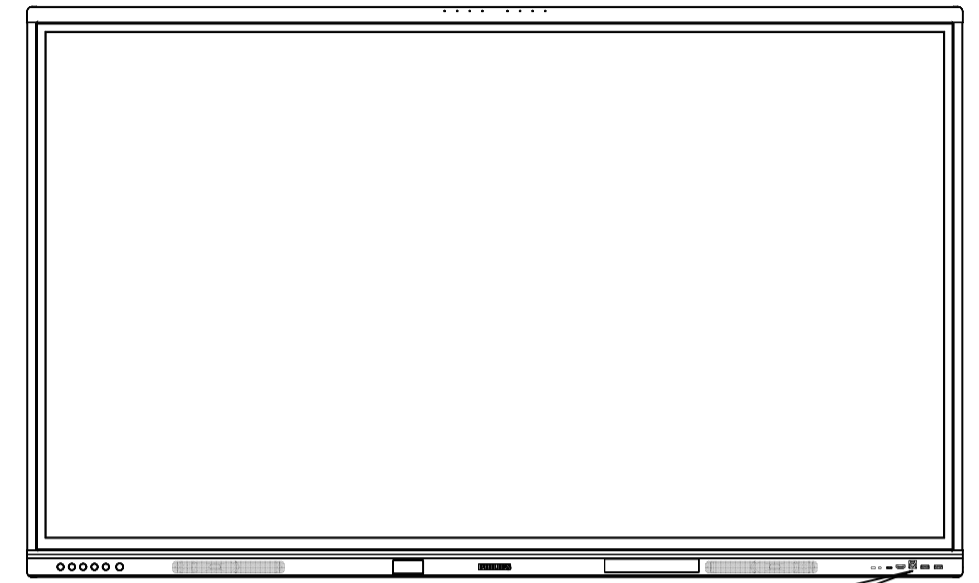

3 Input/Output Terminals

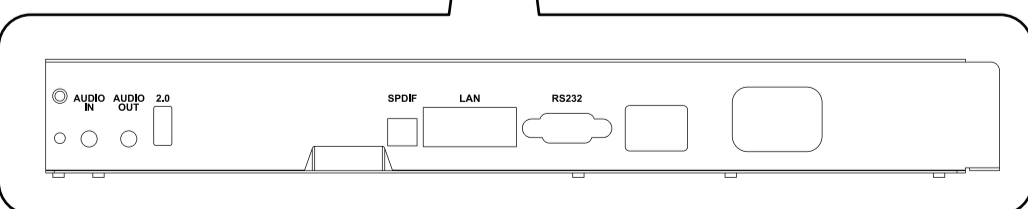
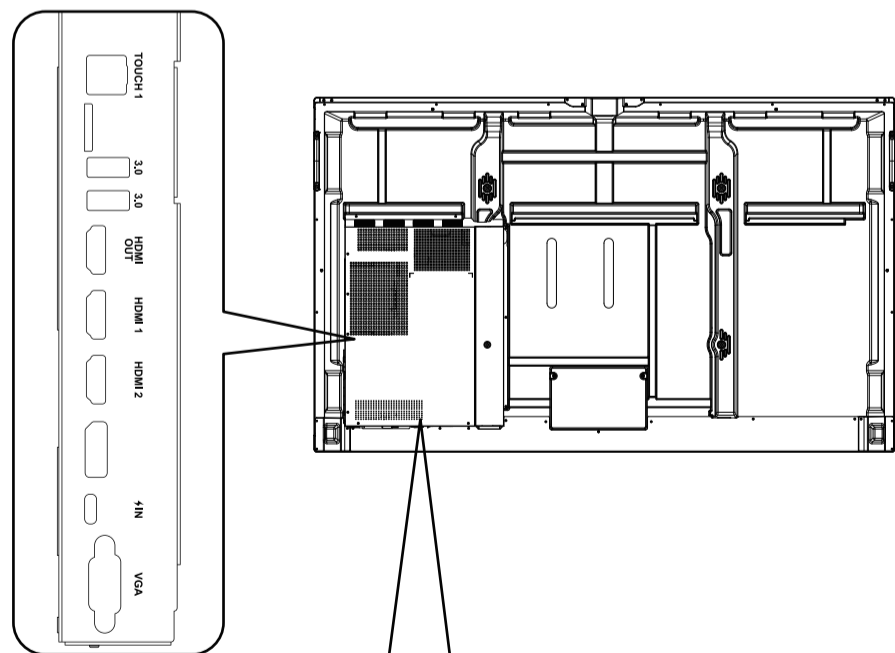

4 Connection

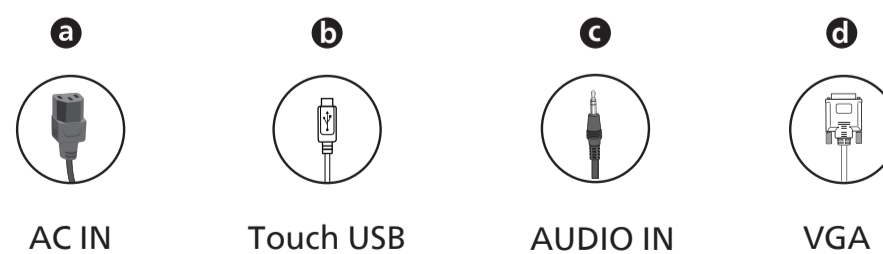
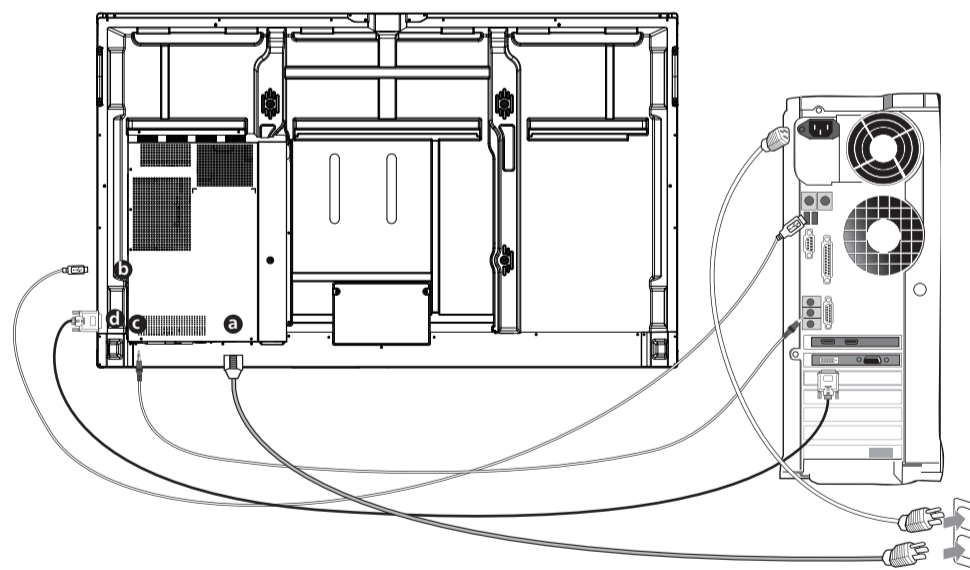

5 Installation

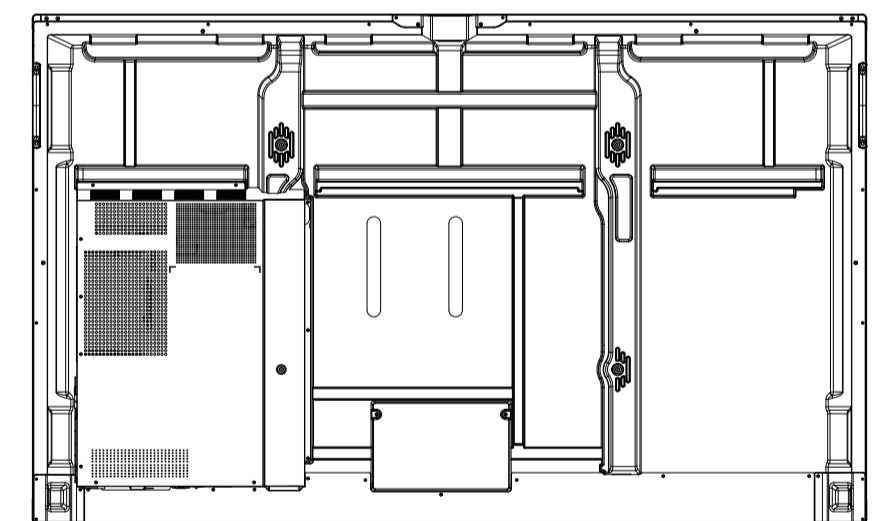
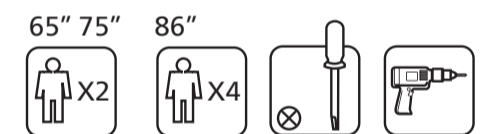

M8 * (10+X) mm
(X=Thickness of Wall Mount BKT)

65BDL4252E : 400mm x 600mm
75BDL4252E : 400mm x 800mm
86BDL4252E : 600mm x 800mm

6 Mounting on a Wall

1. Unpack the wall mount plate and all accessories.

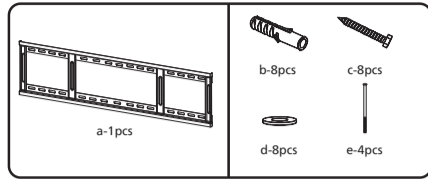

3. Take 8 pcs of expansion rubber plug (b) and screw them into the wall. It is recommended to use a 10 mm impact drill bit to fix them.

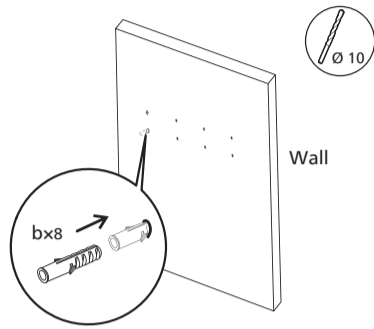

5. Mount the display on the bracket and slide it down vertically. Keep the display in the center of the bracket.

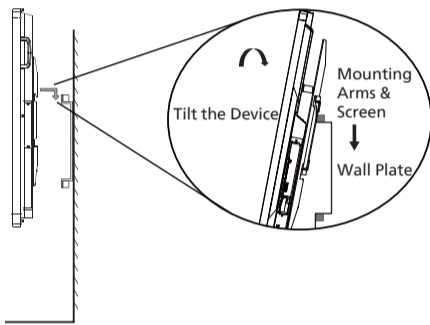

2. Take the display out of the box and place it on a soft surface, such as a mat, to protect it during installation.

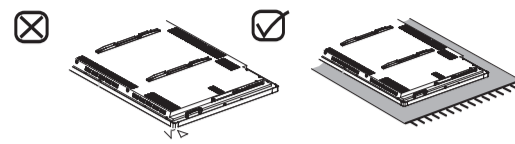

4. Mount the wall bracket (a) to the wall. Thread the screw (c) and gasket (d) through the holes on the bracket and tighten them with the expansion rubber plugs.

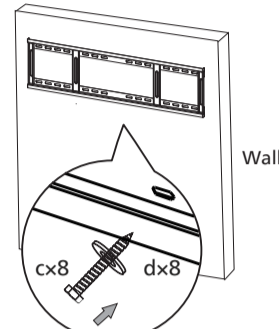

Note: If the wireless module is required, install it before mounting the display to the bracket. (See 7. Installing the wireless module)

6. Tighten the safety screw (e) counterclockwise so the screw at the top position can reach the screw hole at the lower position. This step is important for installation on the mobile stand. Tightening the safety screws can make the device more stable.

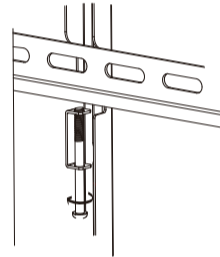

7 Installing the Wireless Module

Please refer to the following steps:

⚠ Please make sure the power cord of the display is disconnected before installation.

Step 1: Remove the Mylar strip on the bottom of the display. Use a Phillips screwdriver to loosen two screws and remove the cover.

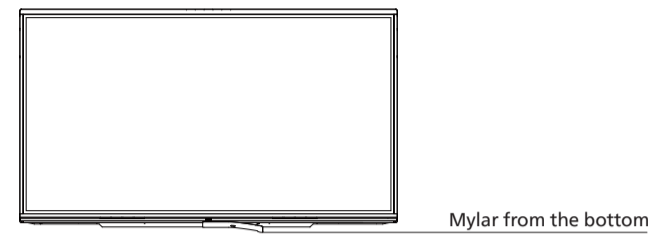

Step 2: Insert the wireless module into the wireless module slot.

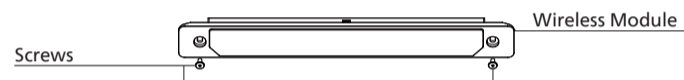
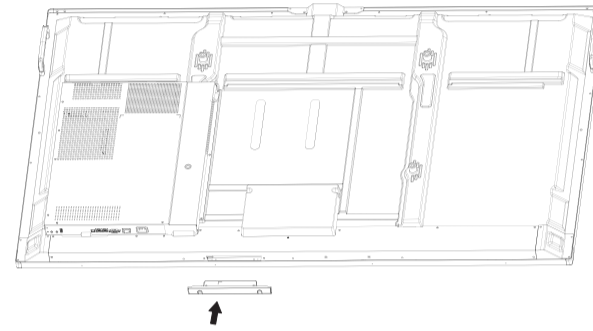

Note: The wireless module works only when it is inserted into the above slot.

PHILIPS

Collaboration
Display

4000 Series

65BDL4252E
75BDL4252E
86BDL4252E

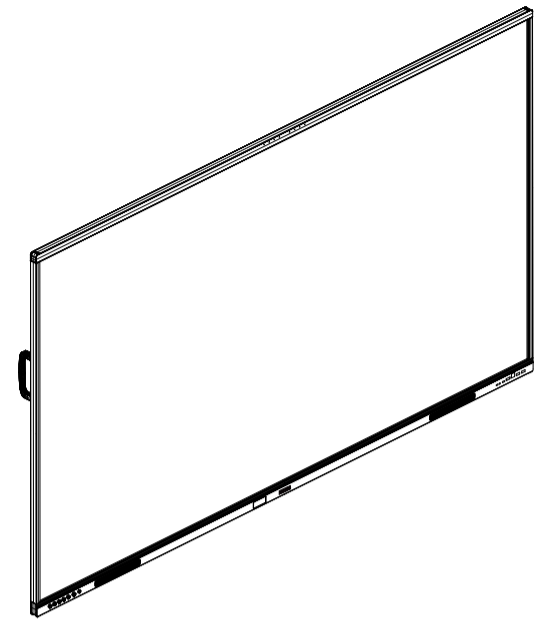

Quick Start



For more information, please visit:
<https://www.philips.com/ppds>



ENERGY STAR is a U.S. Environmental Protection Agency voluntary program that helps businesses and individuals save money and protect our climate through superior energy efficiency. Products that earn the ENERGY STAR prevent greenhouse gas emissions by meeting strict energy efficiency criteria or requirements set by the U.S. Environmental Protection Agency. The above logo appears on all ENERGY STAR-certified models.

This product qualifies for ENERGY STAR in the "Standard mode" setting and this is the setting in which power savings will be achieved.

Changing the Standard mode picture settings or enabling other features will increase power consumption that could exceed the limits necessary to qualify for ENERGY STAR rating.

Refer to EnergyStar.gov for more information on Energy Star program.



Version: V1.00 2025-02-13

TPV USA Corp
6525 Carnegie Blvd #200
Charlotte, NC 28211
USA

2025 © TOP Victory Investments Ltd. All rights reserved.

This product has been manufactured by and is sold under the responsibility of Top Victory Investments Ltd., and Top Victory Investments Ltd. is the warrantor in relation to this product. Philips and the Philips Shield Emblem are registered trademarks of Koninklijke Philips N.V. and are used under license.

Specifications are subject to change without notice.